

# ALUO Survival Guide for Incoming Exchange Students

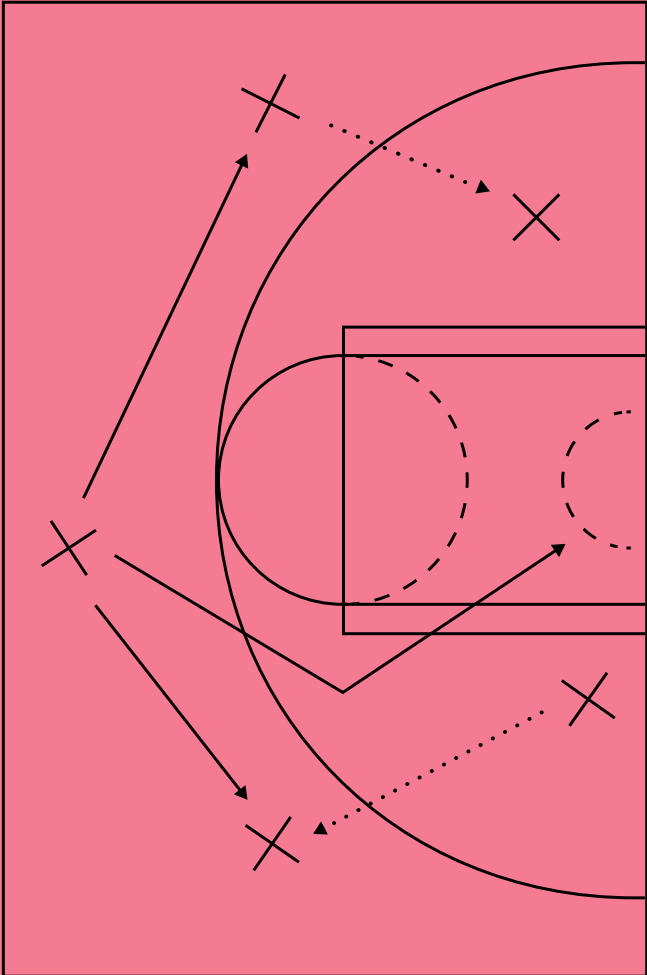

# ALUO Survival Guide for Incoming Exchange Students



This project is funded by  
the European Union



Univerza v Ljubljani  
Akademija za likovno umetnost  
in oblikovanje

## Welcome

Thank you for considering the Academy of Fine Arts and Design of the University of Ljubljana as the host for your student exchange. This guide has been especially designed for foreign students who intend to temporarily study at the academy in an exchange programme.

We hope that this guide will help to make your stay at the academy both fruitful and enjoyable. Should any questions still remain unanswered after reading this guide, please do not hesitate to turn to one of the contact persons mentioned below.

We wish you a pleasant stay in Ljubljana.

*Office for International Cooperation*

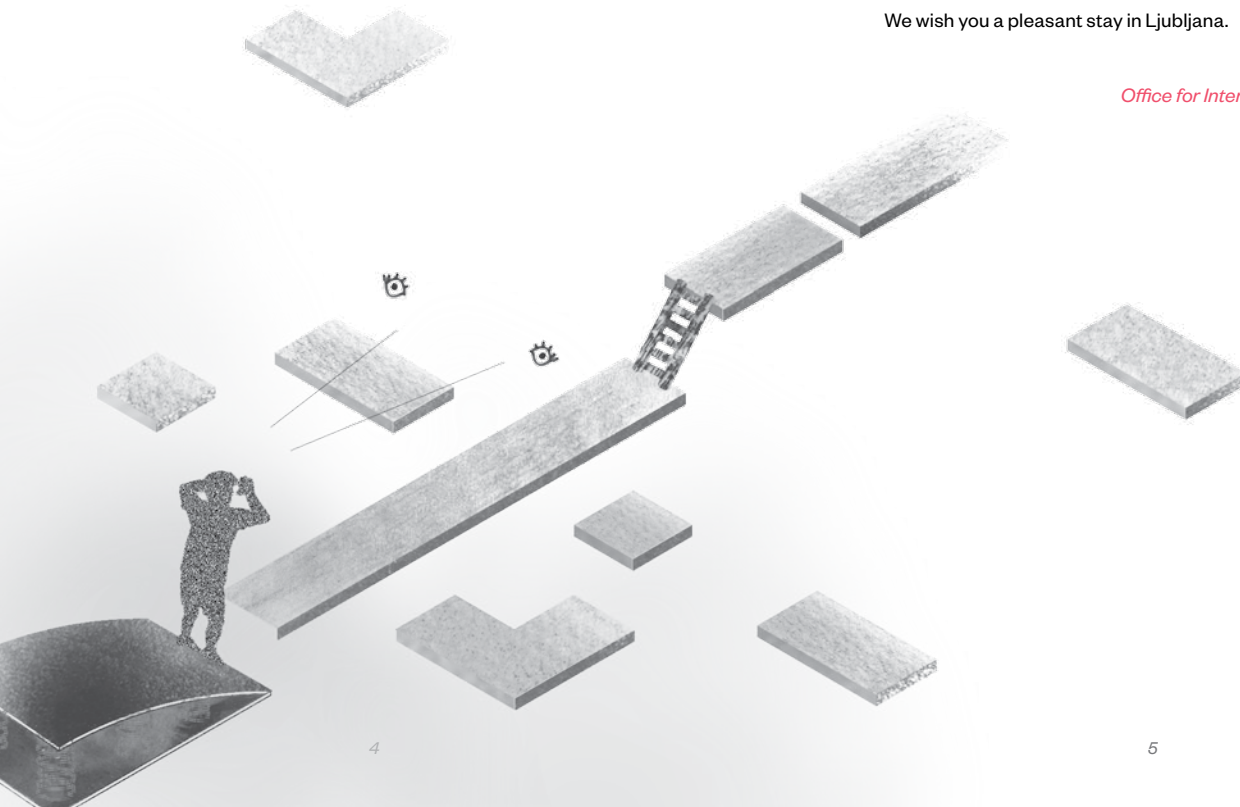

# Content

Welcome	5
About our academy	9
Why study at our academy?	11
Exchange programmes at our academy	13
How to apply for an exchange programme	14
Contacts	20
Locations	24

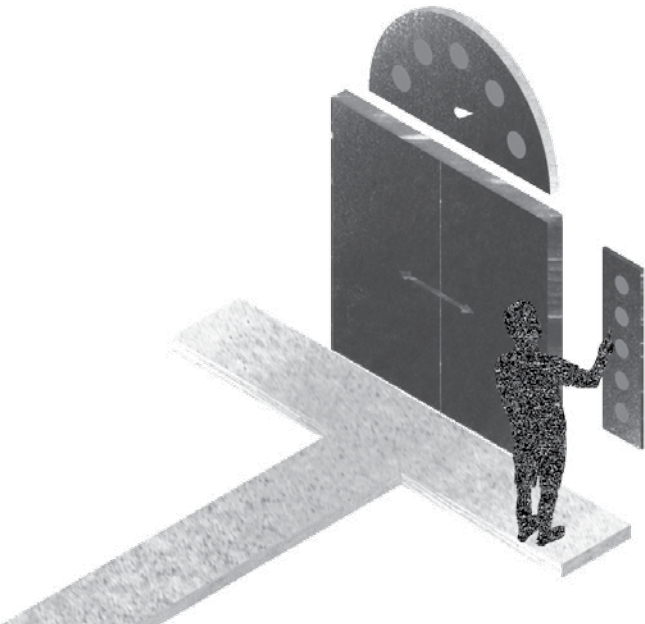

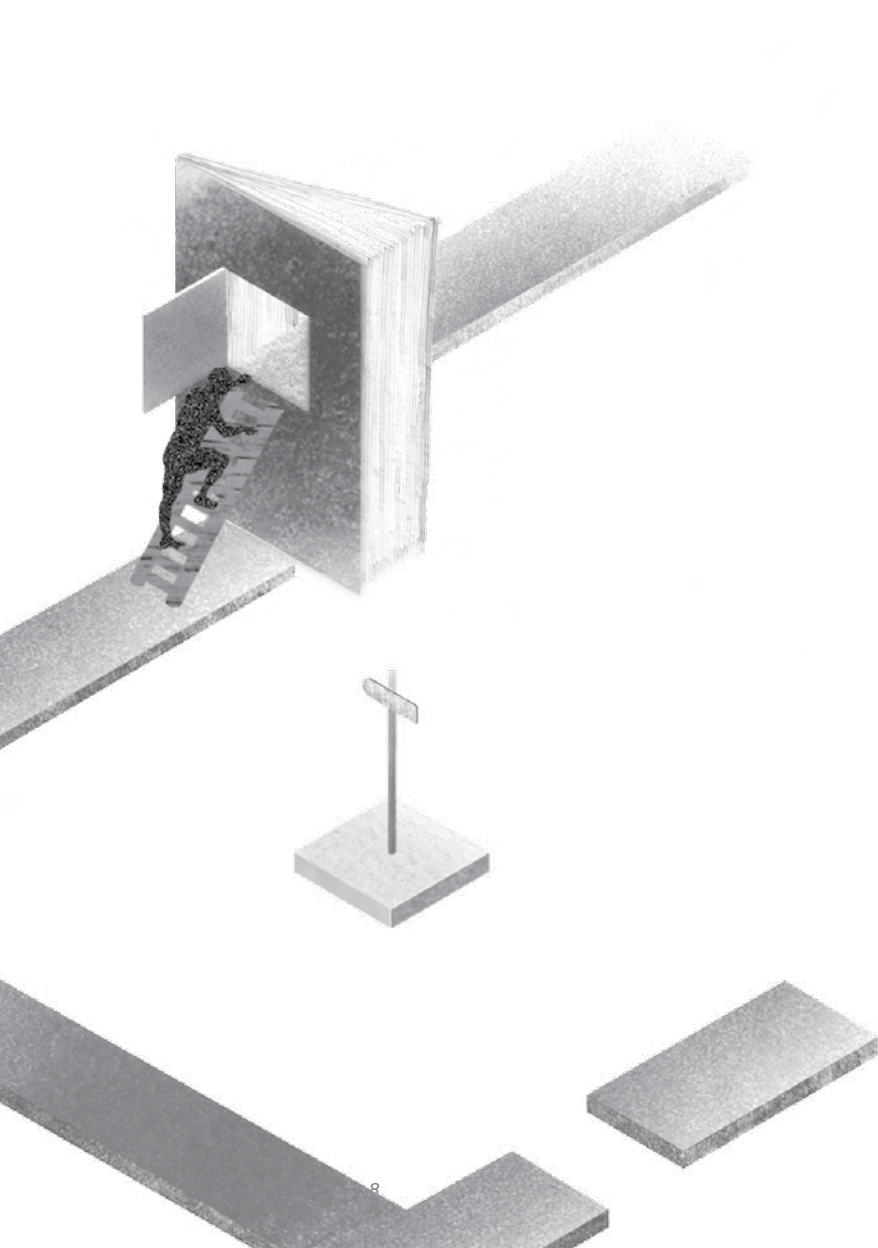

## *About our academy*

ALUO operates within the University of Ljubljana (UL). It is proud of its tradition. It was established on 27 October 1945 as the Academy of Fine Arts, providing courses in painting and sculpture. Throughout the years the Academy changed its name a few times, and expanded its activities in line with its development. In 1984 the studies expanded by incorporating industrial design and visual communications design, and a good ten years later it also introduced conservation/restoration.

Now the courses are organised within five ALUO departments covering the areas of visual arts, conservation/restoration and design. The studies are carried out in small groups, where we develop student creativity and innovation through an individual approach involving consultations, corrections, discussions and seminars, emphasising the importance and the role of our disciplines in the broader social context in order to build individual responsibility. The courses also include theoretical topics and the acquisition of technical and technological skills.

As the extent of our international student exchange is among the largest in comparison with the other institutions within our university, it needs to be emphasised that we cooperate with foreign partners through student exchanges and the inclusion of foreign students in the projects, exhibitions, competitions, conferences, etc.

## *Why study at our academy?*

You will study in a dynamic environment, surrounded by galleries, museums and other cultural institutions;

You will acquire state-of-the-art knowledge about visual arts, conservation/restoration and design taught in an interdisciplinary way, also taking into account other disciplines;

The studies are organised in small groups, emphasising an individual approach and also involving international experts and lecturers;

We provide the training and practical experiences needed for the development of an independent and innovative artist;

As a student you will have the opportunity to participate in several national and international projects, exhibitions, competitions, etc.;

We put you in touch with real professional working environments and professional experts;

We cooperate with national museums and galleries, private galleries, design bureaus and industry;

We encourage student mobility.

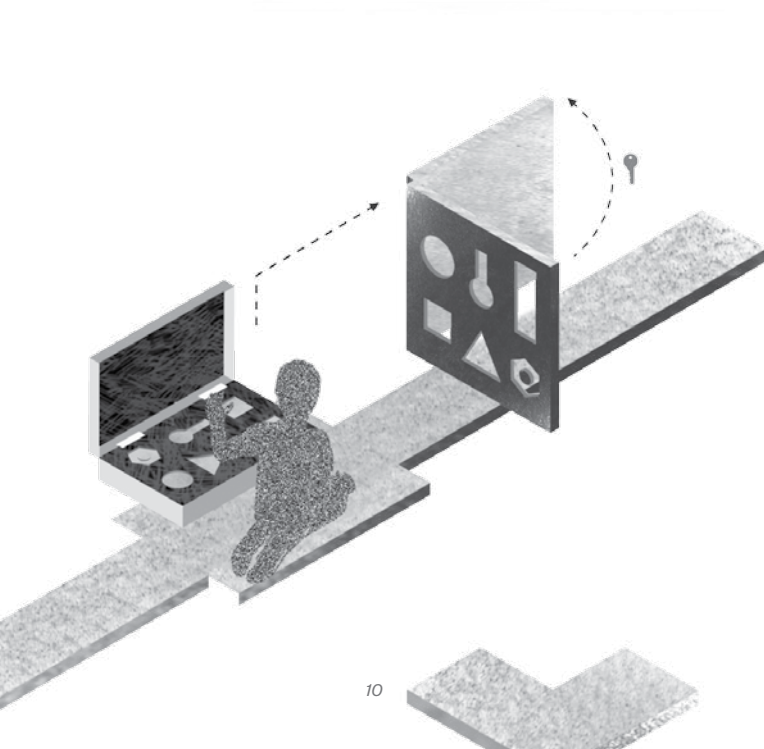

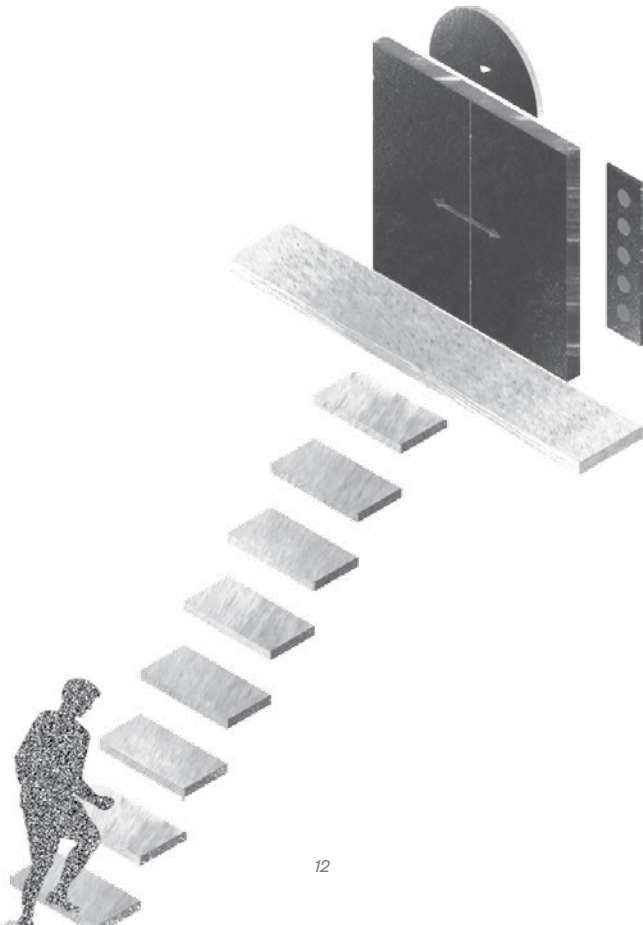

## *Exchange programmes at our academy*

The growth of the quality of our study programmes, the possibility of comparing our achievements with those attained by foreign establishments, informing our students and teachers on the study systems abroad, and increasing public awareness about ourselves - all this urges us to continue and even deepen all possible ways of cooperation with foreign higher education institutions similar to ours. Our international activity is being enriched by permanent cooperation with numerous academies and faculties within the exchange programmes, in particular the Erasmus+ programme. Foreign experts also lecture regularly in various programmes as a result of individual initiatives and informal arrangements.

### ERASMUS+

Erasmus+ brings together seven existing EU programmes in the fields of Education, Training, and Youth; it will for the first time provide support for Sport. As an integrated programme, Erasmus+ offers more opportunities for cooperation across the Education, Training, Youth, and Sport sectors and is easier to access than its predecessors, with simplified funding rules.

### CEEPUS

CEEPUS is an acronym for "Central European Exchange Programme for University Studies". Current member countries are: Albania, Austria, Bosnia and Herzegovina, Bulgaria, Croatia, the Czech Republic, Hungary, Macedonia, Moldova, Montenegro, Poland, Romania, Serbia, the Slovak Republic and Slovenia. Pristina/Kosovo is also participating.

CEEPUS programme supports scholarships to individuals within an approved network of major higher education institutions from different participating countries which then exchange students and professors.

# How to apply for an exchange programme

## DEADLINES FOR ERASMUS EXCHANGE

Exchange students apply twice a year:

15 May – winter semester and full year

15 November – summer semester

In addition to the on-line application, it is obligatory to submit a portfolio to the following e-mail address:

[jasmina.zajc@aluo.uni-lj.si](mailto:jasmina.zajc@aluo.uni-lj.si)

You will be informed about our decision within 8 weeks.

## RECOMMENDED LANGUAGE SKILLS

The minimum required level of English for studying at the Academy of Fine Arts and Design is B2.

## VISA

Information and assistance can be provided by the following contact points and information sources:

INCOMING STUDENTS:

E-mail: [intern.office@uni-lj.si](mailto:intern.office@uni-lj.si)

Telephone: 00 386 1 241 85 92

OUTGOING STUDENTS:

E-mail: [student.office@uni-lj.si](mailto:student.office@uni-lj.si)

Telephone: 00 386 1 241 85 94

## UNIVERSITY OF LJUBLJANA'S WEBSITE:

<http://www.uni-lj.si/eng/>

# Academic Calendar

## SEMESTER 1 (WINTER SEMESTER):

Duration: beginning of October to mid January

Final examinations: mid January to mid February

## SEMESTER 2 (SUMMER SEMESTER):

Duration: mid February to beginning of June

Final examinations: beginning of June to beginning of July

## SELECTION OF COURSES

Courses can be selected only from the list of courses of all departments. At the end of the semester students obtain grades and credit points for each selected course.

The Academy of Fine Arts and Design doesn't offer courses in English. We suggest that incoming students choose practical courses, where individual consultations in English with professors are possible. Please note that your level of English knowledge should be at least intermediate!

## MEDICAL INSURANCE

Foreign students coming from the EU member countries and the countries of the European economic region should have the E 128 form, E 111 form or E-card. The document type depends on the authorized insurance agency of the country of their origin. Namely, the students should contact the authorized insurance agency, where they have been insured, and ask for one of the above-mentioned forms. If you have no health insurance in your home country, you can contact the insurance company that will cover your insurance in the Republic of Slovenia (ASSISTANCE CORIS, Ul. Bratov Babnik 10, 1000 Ljubljana, tel.: +386 1 519 20 20, fax: +386 1 519 16 98, Email: [coris@coris.si](mailto:coris@coris.si))



# Accommodation

## STUDENT DORMITORIES

Erasmus students can apply for a bed in student dormitories. They are given to students on "first come first serve" basis. The rooms in the dormitories are double, with bathroom and shared kitchen. The access to internet is available in almost all the dormitories.

The Housing Form students will be able to send upon filling out online application by 15 May (first semester) or 15 November (second semester).

## TEMPORARY ACCOMMODATION

Below are the addresses of some cheaper hostels in Ljubljana, where you can book a room for the first week/month of your stay in Ljubljana and during that time you will be able to look for private accommodation by yourself.

Hostel CELICA, metelkova 8, 1000 Ljubljana

Website: <http://www.hostelcelica.com>

Hotel EMONEC, Wolfova 12, 1000 Ljubljana

Website: <http://www.hotel-emonec.com>

Hotel PARK/ Hostel PARK, Tabor 9, 1000 Ljubljana

Website: [http://www.hotelpark.si/en\\_home,7.html](http://www.hotelpark.si/en_home,7.html)

Youth Hostel Ljubljana (BIT), Litjiska 57, 1000 Ljubljana

Website: <http://www.bit-center.net>

Aladin Hostel, Tugomerjeva 56, 1000 Ljubljana

Website: <http://www.aladin-hostel.com>

CHECK OUT THESE WEB SITES AS WELL:

<http://www.visitljubljana.si/en/accommodation/>

<http://www.nepremicnine.net/>

## PRIVATE ACCOMMODATION

The Student Organization of the University of Ljubljana will help you find private accommodation after your arrival to Ljubljana. They will provide you with some addresses, give you some advice, but the search will be done by you. Before your departure you should book yourself a hostel for the first few nights. After the arrival you can visit the International Office of the Student Organization (Kampus, Pivovarniška 6, office hours: Tuesday 2pm-5pm, Wednesday 2pm - 5pm, Thursday 2pm - 5pm ), but firstly you should contact them by e-mail: [rooms@sou-lj.si](mailto:rooms@sou-lj.si); [findmeroom@gmail.com](mailto:findmeroom@gmail.com)

## HOUSINGANYWHERE

Use HousingAnywhere platform to rent out your room to an incoming exchange student and get a room in Ljubljana.

<https://www.housinganywhere.com/>

This website is free to use and it operates on a student-to-student basis. For any questions, please contact :

[info@housinganywhere.com](mailto:info@housinganywhere.com)

## *Slovene language course for Erasmus+ students*

What: 60 hours course, 3 ECTS

When: in September for winter semester and in  
mid January till mid February for Spring semester.

Where: Faculty of Arts, Aškerčeva 2,  
Ljubljana price: 75€ (textbook included in the price)

Application form and more information:

<http://centerslo.si/en/>

(exact dates will be given later)

## *After Your Arrival*

### **AFTER YOUR ARRIVAL YOU SHOULD VISIT:**

The Office of International Relations of the University,  
Kongresni trg 12, office hours: 8:30 – 11:30, where you  
will get your student card and further instructions;

The Office for International Cooperation of the Academy  
of Fine Arts and Design, Erjavčeva 23, office hours:  
Monday, Tuesday and Thursday from 10.00 to 12.00  
Wednesday from 14:00 to 17:00, where you will get all  
the information regarding your study programme.

### **STUDENT ORGANIZATION**

International office of the Student Organization of the  
University of Ljubljana (ŠOU of Ljubljana), Kersnikova 4, will  
help you with more practical information regarding meal  
coupons, city bus card, sports, social programme, trips.  
You can find out more about it on the web site:

<http://www.sou-lj.si/sl/international-students>

# Contacts

## ACADEMY OF FINE ARTS AND DESIGN UNIVERSITY OF LJUBLJANA

Erjavčeva 23, SI-1000 Ljubljana, Slovenia

Phone: +386 1 421 25 00

Fax: +386 1 251 90 71

E-mail: [dekanat@aluo.uni-lj.si](mailto:dekanat@aluo.uni-lj.si)

## DEPARTMENT OF PAINTING DEPARTMENT OF SCULPTURE

Erjavčeva 23, SI-1000 Ljubljana, Slovenia

Phone: +386 1 421 25 00

Fax: +386 1 251 90 71

## DEPARTMENT OF RESTORATION

Svetčeva 1, SI-1000 Ljubljana

Phone: +386 1 421 25 00

## DEPARTMENT OF INDUSTRIAL DESIGN AND APPLIED ARTS

Dolenjska cesta 83, SI-1000 Ljubljana

Phone: +386 1 421 25 20

Fax: +386 1 427 25 93

## DEPARTMENT OF VISUAL COMMUNICATION DESIGN

Dolenjska cesta 83, SI-1000 Ljubljana

Phone: +386 1 421 25 20

Fax: +386 1 427 25 93

## DEAN

mag. Lucija Močnik Ramovš, Associate Professor

[dean@aluo.uni-lj.si](mailto:dean@aluo.uni-lj.si)

## VICE-DEAN OF STUDENT AFFAIRS

Domen Fras, Associate Professor

[domen.fras@aluo.uni-lj.si](mailto:domen.fras@aluo.uni-lj.si)

## VICE-DEAN OF DEVELOPMENT

Sašo Sedlaček, Associate Professor

[saso.sedlacek@aluo.uni-lj.si](mailto:saso.sedlacek@aluo.uni-lj.si)

## VICE-DEAN FOR INTERNATIONAL COOPERATION AND COLLABORATION WITH THE ECONOMY

Petra Černe Oven, PhD, Associate Professor

[petra.cerneoven@aluo.uni-lj.si](mailto:petra.cerneoven@aluo.uni-lj.si)

## ACADEMY SECRETARY-GENERAL

Matej Zonta

[matej.zonta@aluo.uni-lj.si](mailto:matej.zonta@aluo.uni-lj.si)

Phone: +386 1 421 25 11

## *STUDENT AFFAIRS OFFICE*

### UNDERGRADUATE STUDIES

Barbara Kalan

[barbara.kalan@aluo.uni-lj.si](mailto:barbara.kalan@aluo.uni-lj.si)

Phone: +386 1 421 25 01

### POSTGRADUATE STUDIES AND INTERNATIONAL COOPERATION

Jasmina Zajc

[jasmina.zajc@aluo.uni-lj.si](mailto:jasmina.zajc@aluo.uni-lj.si)

Phone: +386 1 421 25 02

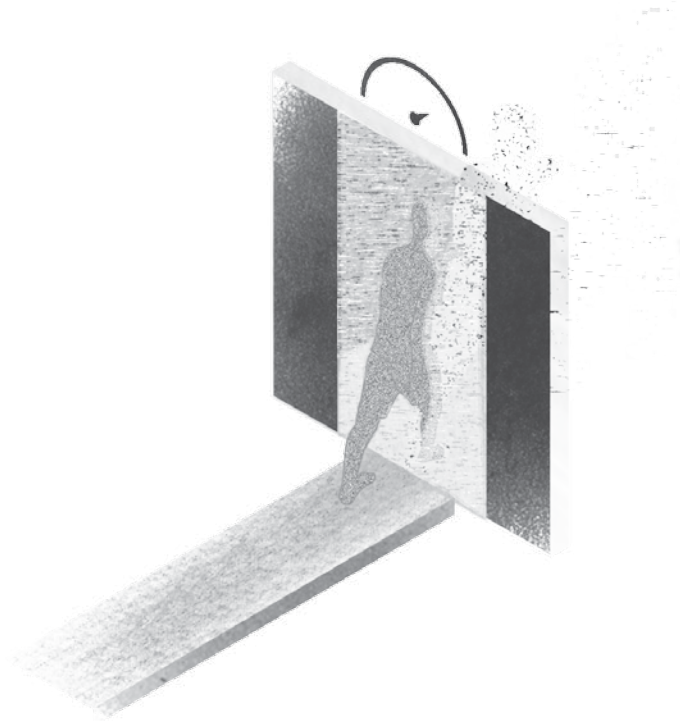

# Locations of Academy of Fine Arts and Design

## **ALUO 1**

DEPARTMENT OF PAINTING  
DEPARTMENT OF SCULPTURE

Erjavčeva 23, SI-1000 Ljubljana  
Phone: +386 1 421 25 00  
Fax: +386 1 251 90 71



## **ALUO 2**

DEPARTMENT OF RESTORATION

Svetčeva 1, SI-1000 Ljubljana  
Phone: +386 1 421 76 80



## **ALUO 3**

DEPARTMENT OF INDUSTRIAL DESIGN AND APPLIED ARTS  
DEPARTMENT OF VISUAL COMMUNICATION DESIGN

Dolenjska cesta 83, SI-1000 Ljubljana  
Phone: +386 1 421 25 20  
Fax: +386 1 427 25 93



University of Ljubljana  
Academy of Fine Arts and Design  
© 2018

Published by the Academy of Fine Arts and Design  
University of Ljubljana, Erjavčeva 23, SI-1000 Ljubljana, Slovenia

Edited by Jasmina Zajc and Lucija Močnik Removš  
Illustration by Blažka Jurjavčič  
Publication design by Emil Kozole  
Printed by Matformat  
Ljubljana 2018

Publication supported by Erasmus+

